

**SINGER®**

***3342 Instruction Manual***



# IMPORTANT SAFETY INSTRUCTIONS

This household sewing machine is designed to comply with IEC/EN 60335-2-28 and UL1594.

## IMPORTANT SAFETY INSTRUCTIONS

When using an electrical appliance, basic safety precautions should always be followed, including the following:

Read all instructions before using this household sewing machine. Keep the instructions in a suitable place close to the machine. Make sure to hand them over if the machine is given to a third party.

### **DANGER - To reduce the risk of electric shock :**

- A sewing machine should never be left unattended when plugged in. Always unplug this sewing machine from the electric outlet immediately after using and before cleaning, removing covers, lubricating or when making any other user servicing adjustments mentioned in the instruction manual.

### **WARNING - To reduce the risk of burns, fire, electric shock, or injury to person :**

- Do not allow to be used as a toy. Close attention is necessary when this sewing machine is used by or near children.
- Use this sewing machine only for its intended use as described in this manual. Use only attachments recommended by the manufacturer as contained in this manual.
- Never operate this sewing machine if it has a damaged cord or plug, if it is not working properly, if it has been dropped or damaged, or dropped into water. Return the sewing machine to the

nearest authorized dealer or service center for examination, repair, electrical or mechanical adjustment.

- Never operate the sewing machine with any air openings blocked. Keep ventilation openings of the sewing machine and foot control free from the accumulation of lint, dust, and loose cloth.
- Keep fingers away from all moving parts. Special care is required around the sewing machine needle.
- Always use the proper needle plate. The wrong plate can cause the needle to break.
- Do not use bent needles.
- Do not pull or push fabric while stitching. It may deflect the needle causing it to break.
- Wear safety glasses.
- Switch the sewing machine off (“O”) when making any adjustment in the needle area, such as threading needle, changing needle, threading bobbin, or changing presser foot, etc.
- Never drop or insert any object into any opening.
- Do not use outdoors.
- Do not operate where aerosol (spray) products are being used or where oxygen is being administered.
- To disconnect, turn all controls to the off (“O”) position, then remove plug from outlet.
- Do not unplug by pulling on cord. To unplug, grasp the plug, not the cord.
- The foot control is used to operate the machine. Avoid placing other objects on the foot control.
- Do not use the machine if it is wet.
- If the LED lamp is damaged or broken, it must be replaced by the manufacturer or its service agent or a similarly qualified person, in order to avoid a hazard.
- If the supply cord connected with the foot control is damaged, it must be replaced by the manufacturer or its service agent or a similarly qualified person, in order to avoid a hazard.
- This sewing machine is provided with double insulation. Use only identical replacement parts. See instructions for Servicing of Double-Insulated Appliances.

# **SAVE THESE INSTRUCTIONS**

## **For Europe only :**

This appliance can be used by children aged from 8 years and above and persons with reduced physical, sensory or mental capabilities or lack of experience and knowledge if they have been given supervision or instruction concerning use of the appliance in a safe way and understand the hazards involved. Children shall not play with the appliance. Cleaning and user maintenance shall not be made by children without supervision.

The noise level under normal operating conditions is less than 75dB(A).

The machine must only be used with foot control of type KD-1902, FC-1902 (110-120V area) / KD-2902, FC-2902A, FC-2902C, FC-2902D (220-240V area) manufactured by ZHEJIANG FOUNDER MOTOR CORPORATION LTD. (China) / 4C-316B (110-125V area) / 4C-316C (127V area) / 4C-326C (220V area) / 4C-326G (230V area) / 4C-336G (240V area) / 4C-336G (220-240V area) manufactured by Wakaho Electric Ind. Co., Ltd. (Vietnam)

## **For outside Europe :**

This sewing machine is not intended for use by persons (including children) with reduced physical, sensory or mental capabilities, or lack of experience and knowledge, unless they have been given supervision or instruction concerning use of the sewing machine by a person responsible for their safety. Children should be supervised to ensure that they do not play with the sewing machine.

The noise level under normal operating conditions is less than 75dB(A).

The machine must only be used with foot control of type KD-1902, FC-1902 (110-120V area) / KD-2902, FC-2902A, FC-2902C, FC-2902D (220-240V area) manufactured by ZHEJIANG FOUNDER MOTOR CORPORATION LTD. (China) / 4C-316B (110-125V area) / 4C-316C (127V area) / 4C-326C (220V area) / 4C-326G (230V area) / 4C-336G (240V area) / 4C-336G (220-240V area) manufactured by Wakaho Electric Ind. Co., Ltd. (Vietnam)

## **SERVICING OF DOUBLE INSULATED PRODUCTS**

In a double-insulated product, two systems of insulation are provided instead of grounding. No ground means is provided on a double-insulated product, nor should a means for grounding be added to the product. Servicing of a double-insulated product requires extreme care and knowledge of the system and should be done only by qualified service personnel. Replacement parts for a double-insulated product must be identical to those parts in the product. A double-insulated product is marked with the words "DOUBLE INSULATION" or "DOUBLE INSULATED".

## **Congratulations**

As the owner of a new SINGER® sewing machine, you are about to begin an exciting adventure in creativity. From the moment you first use your machine, you will know you are sewing on one of the easiest to use sewing machines ever made.

May we recommend that, before you start to use your sewing machine, you discover the many features and the ease of operation by going through this instruction book, step by step, seated at your machine.

To ensure that you are always provided with the most modern sewing capabilities, the manufacturer reserves the right to change the appearance, design or accessories of this sewing machine when considered necessary.

SINGER® is the exclusive trademark of The Singer Company Limited S.à.r.l. or its Affiliates.

©2016 The Singer Company Limited S.à.r.l. or its Affiliates. All rights reserved.

## List of contents

---

### **Machine Basics**

Principal Parts of the Machine .....	1-2
Connecting Machine to Power Source .....	3
Two Step Presser Foot Lifter .....	4
Accessories .....	5

### **Treading the Machine**

Winding the Bobbin .....	6
Inserting the Bobbin .....	7
Threading the Upper Thread .....	8
Automatic Needle Threader .....	9
Raising the Bobbin Thread .....	10
Thread Tension .....	11

### **Sewing**

How to Choose Your Pattern .....	12
Stitch Width Dial & Stitch Length Dial .....	13
Sewing Straight Stitch .....	14
Reverse Sewing .....	15
Removing the Work .....	15
Cutting the Thread .....	15
Choosing Stretch Stitch Patterns .....	16
Blind Hem .....	17
Buttonholes .....	18
Sewing on Buttons .....	19

### **General Information**

Installing the Removable Extension Table .....	20
Changing the presser foot .....	21
Needle/ Fabric/ Thread Chart .....	22
Darning plate .....	23

### **Maintenance and Troubleshooting**

Inserting the needle .....	24
Cleaning the Feed Teeth and Hook Area .....	25
Troubleshooting Guide .....	26



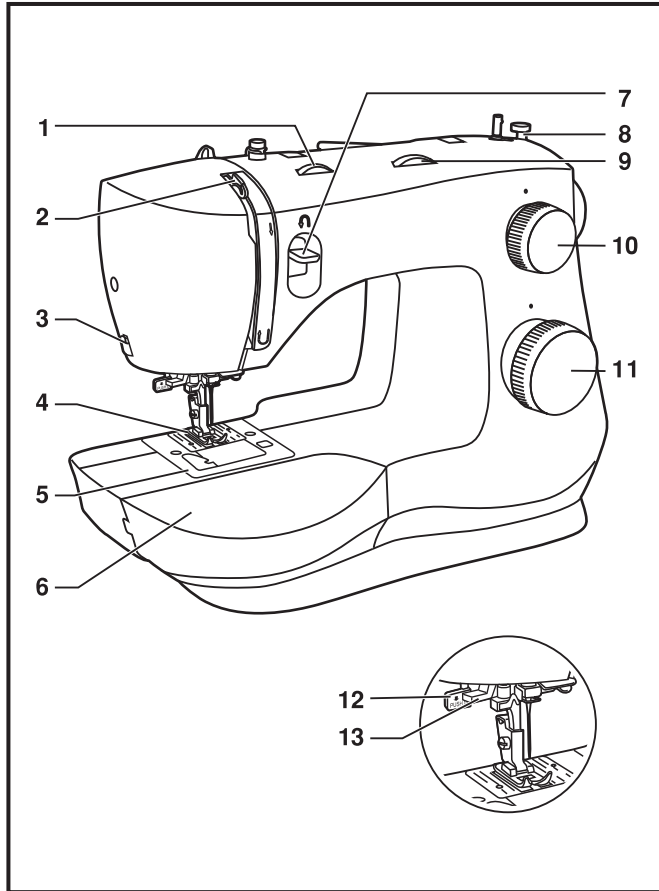

## □ Principal Parts of the Machine

1. Thread tension dial
2. Thread take-up lever
3. Thread cutter
4. Presser foot
5. Needle plate
6. Removable extension table/ accessory storage
7. Reverse sewing lever
8. Bobbin stopper
9. Stitch width dial
10. Stitch length dial
11. Pattern selector dial
12. One step buttonhole lever
13. Automatic threader

### Unpacking

- Place the box on a steady, flat surface. Lift your machine out of the box and remove the outer packaging.
- Remove all other packing material and the plastic bag.

## □ Principal Parts of the Machine

---

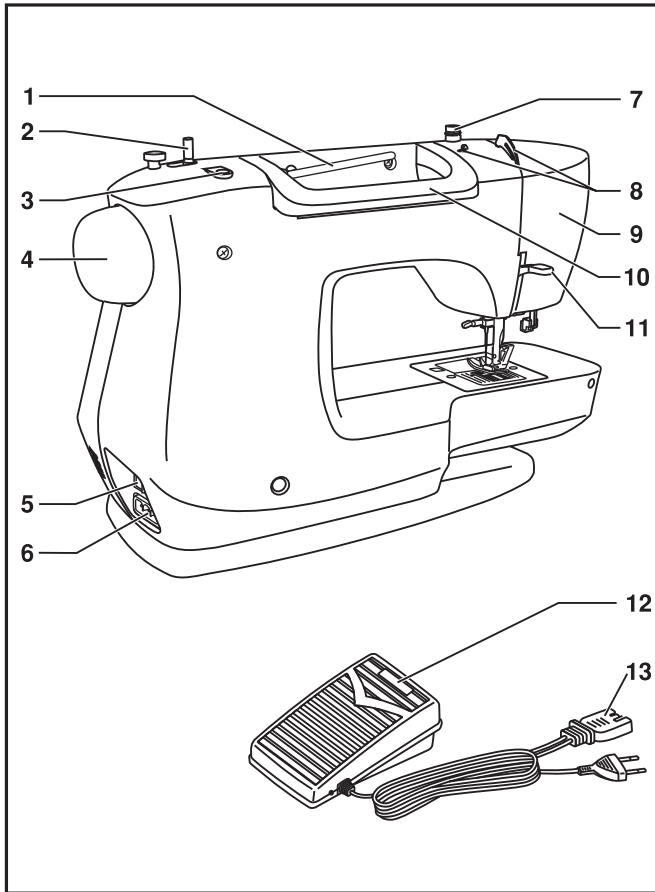

1. Horizontal spool pin
2. Bobbin winding spindle
3. Hole for auxiliary spool pin
4. Handwheel
5. Power and light switch
6. Main plug socket
7. Bobbin thread guide
8. Upper thread guide
9. Face plate
10. Handle
11. Presser foot lifter
12. Foot speed control
13. Power cord

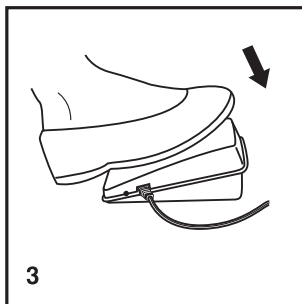
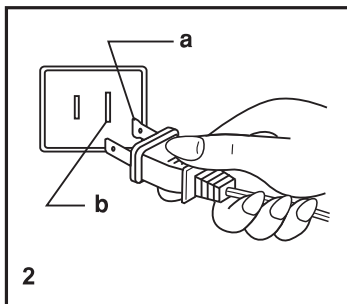
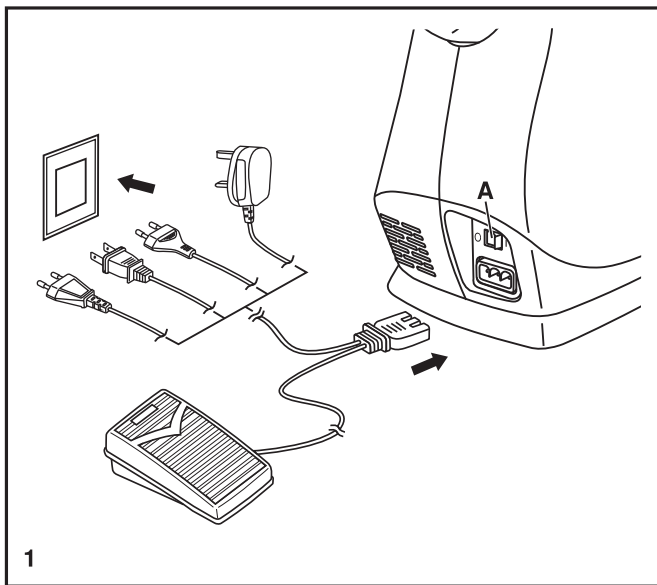

## □ Connecting Machine to Power Source

Connect the machine to a power source as illustrated. (1)  
This appliance is equipped with a polarized plug which must be used with the appropriate polarized outlet. (2)

### Attention:

Unplug power cord when machine is not in use.

### Foot control

The foot control pedal regulates the sewing speed. (3)

### Attention:

Consult a qualified electrician if in doubt of how to connect machine to power source.

### Sewing light

Press main switch (A) to "I" for power and light.

### IMPORTANT NOTICE

For appliance with a polarized plug (one blade is wider than the other). To reduce the risk of electric shock, this plug is intended to fit in a polarized outlet only one way. If it does not fit fully in the outlet, reverse the plug. If it still does not fit, contact a qualified electrician to install the proper outlet. Do not modify the plug in any way.

- a. Polarized attachment plug
- b. Conductor intended to be grounded

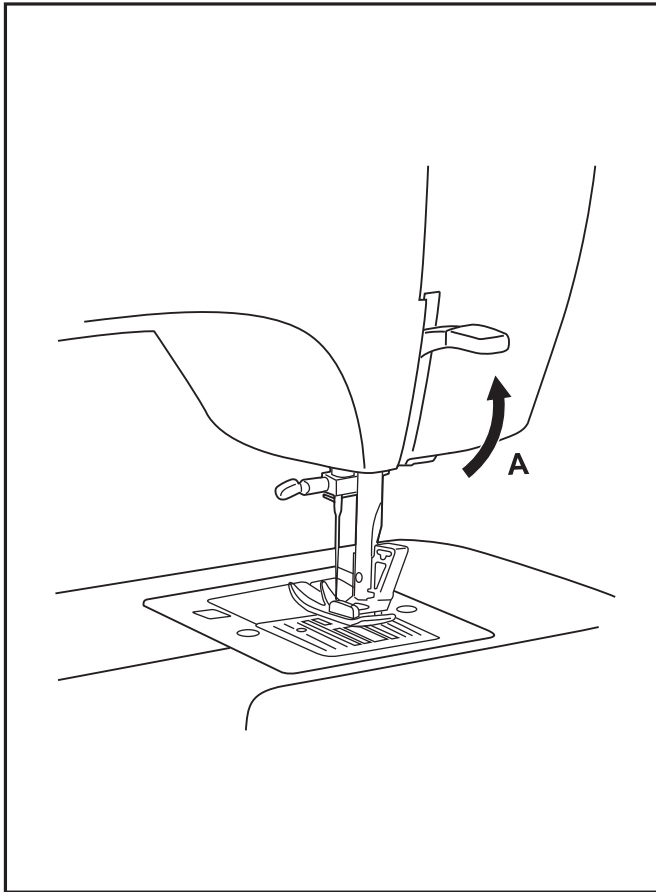

## Two Step Presser Foot Lifter

When sewing several layers or thick fabrics, the presser foot can be raised to a higher position for easy positioning of the work. (A)

### **Attention:**

Your SINGER® machine is adjusted to provide the best stitch result at normal room temperature. Extreme hot and cold temperatures can affect the sewn result.

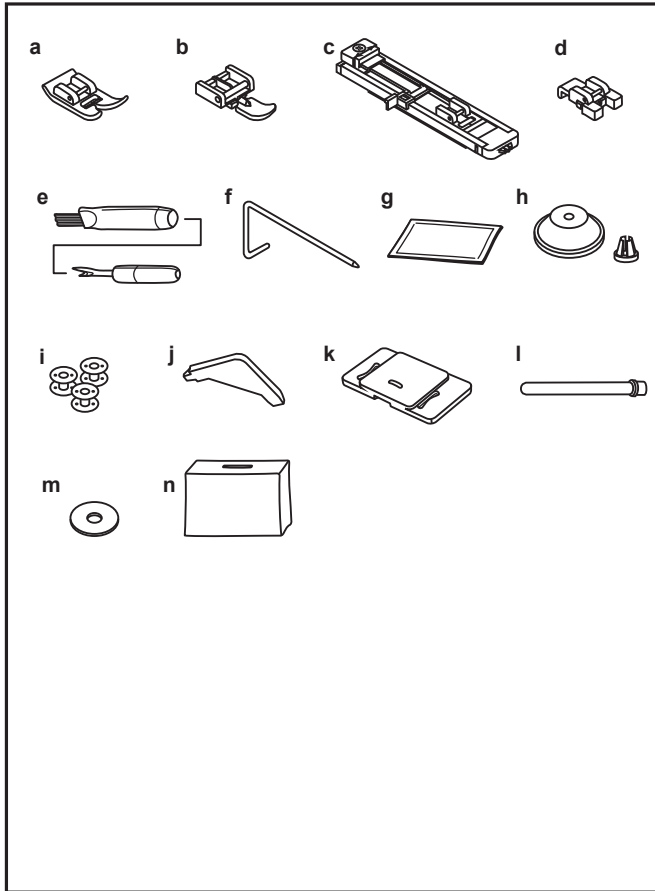

## □ Accessories

### Standard accessories

- a. All purpose foot
- b. Zipper foot
- c. Buttonhole foot
- d. Button sewing foot
- e. Seam ripper/ brush
- f. Edge/ quilting guide
- g. Pack of needles
- h. Spool holders
- i. Bobbin (3x)
- j. L-screwdriver
- k. Darning plate
- l. Auxiliary Spool Pin
- m. Spool pin felt
- n. Soft cover

### Optional Accessories:

For information about additional presser feet, attachments and accessories that may be available for your machine, visit [www.singer.com](http://www.singer.com).

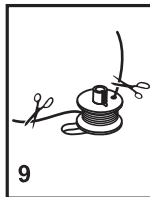
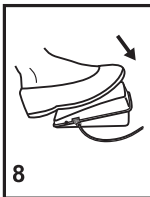
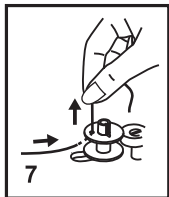
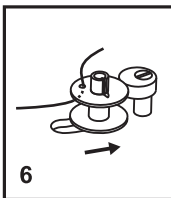
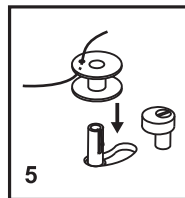
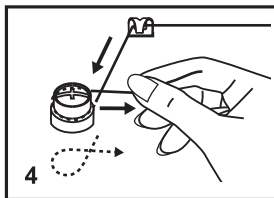
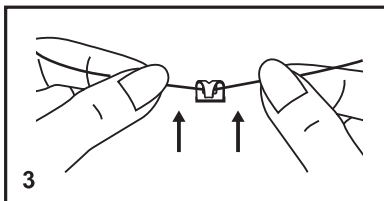
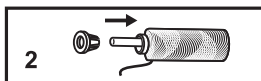
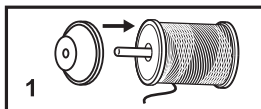
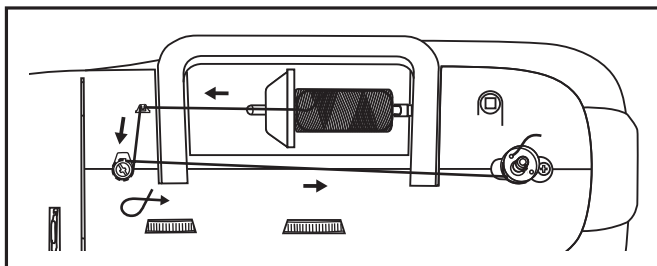

## □ Winding the Bobbin

- Place thread and corresponding spool holder on to spool pin. (1/2)
- Snap thread into thread guide. (3)
- Wind thread clockwise around bobbin winder tension discs. (4)
- Thread bobbin as illustrated and place on spindle. (5)
- Push bobbin spindle to right. (6)
- Hold thread end. (7)
- Step on foot control pedal. (8)
- Cut thread. (9)
- Push bobbin spindle to left (10) and remove.

### **Please Note:**

When the bobbin winder spindle is in “bobbin winding” position, the machine will not sew and the hand wheel will not turn. To start sewing, push the bobbin winder spindle to the left (sewing position).

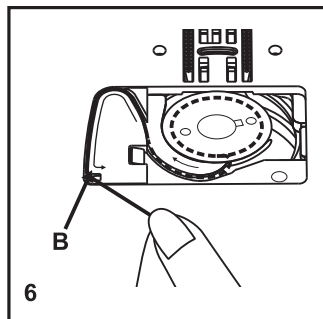
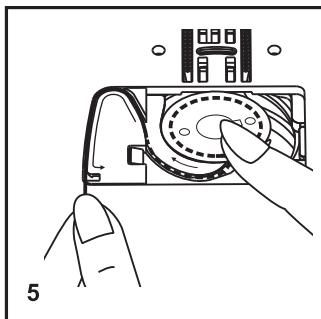
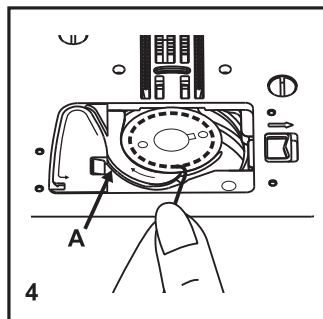
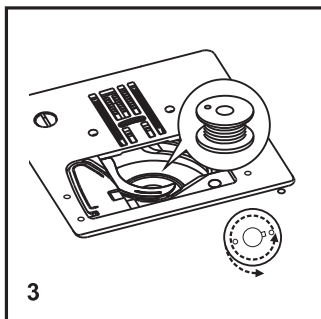
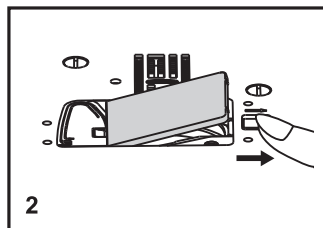
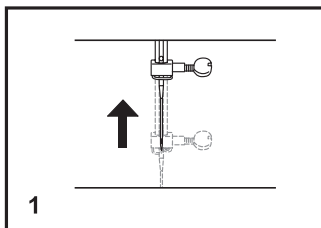

## □ Inserting the Bobbin

- When inserting or removing the bobbin, the needle must be fully raised. (1)
- Remove the bobbin cover plate and bobbin. (2)
- Insert the bobbin in the bobbin case with the thread running in a counterclockwise direction (arrow). (3)
- Pull the thread through the slit (A). (4)
- With a finger held gently on top of the bobbin, place thread into guides as shown. (5)
- To cut off excess thread pull it toward you to cut it with the cutter at point (B). Replace the bobbin cover plate. (6)

### **Attention:**

Turn power switch to off ("O") before inserting or removing the bobbin.

## □ Threading the Upper Thread

This is a simple operation but it is important to carry out correctly as by not doing so several sewing problems could result.

- Start by raising the needle to its highest point (1), and continue turning the handwheel counterclockwise until the needle just slightly begins to descend. Raise the presser foot to release the tension discs.

**Note:** For safety, it is strongly suggested you turn off the power before threading.

- Lift up the spool pin. Place the spool of thread on the holder with the thread coming off the spool as shown. For small thread spools, place small side of spool holder next to spool. (2)
- Draw thread from spool through the upper thread guide (3) and pulling thread through pre-tension spring as illustrated. (4)
- Thread tension module by leading thread down right channel and up left channel. (5) During this process it is helpful to hold the thread between the spool and thread guide.
- At the top of this movement pass thread from right to left through the slotted eye of the take-up lever and then downwards again. (6)
- Now pass the thread behind the horizontal thread guide, and then behind the thin wire needle clamp guide (7) and then down to the needle which should be threaded from front to back.
- Pull about 6-8 inches of thread to the rear beyond the needle eye. Trim thread to length with built in thread cutter. (8)

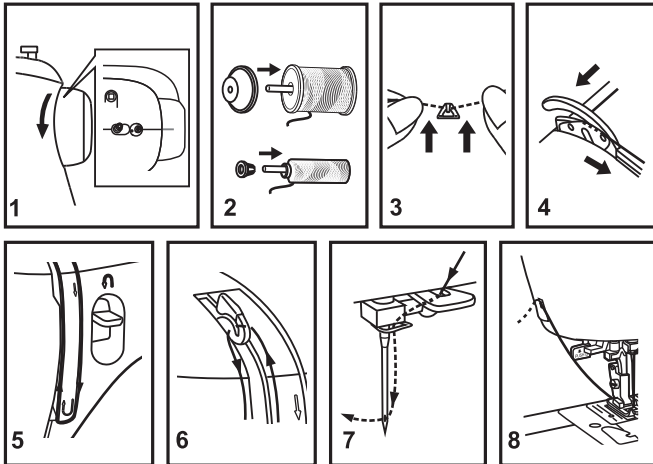
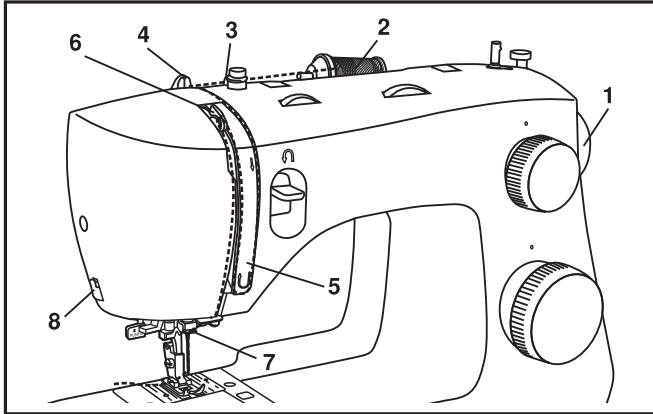



## □ Automatic Needle Threader

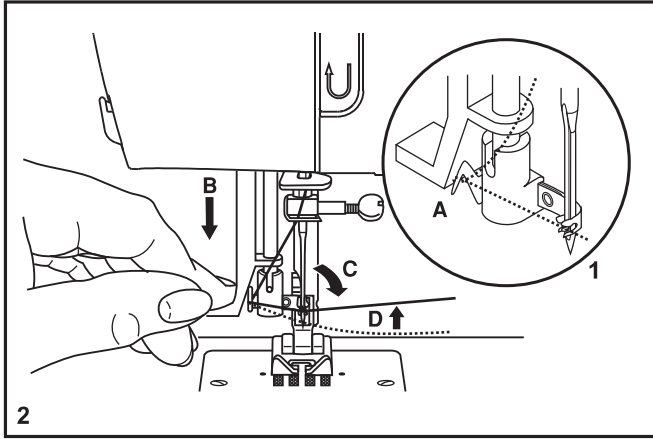

- Raise the needle to its highest position.
- Pass thread around thread guide (A). (1)
- Press lever (B) down as far as it will go. (2)
- The threader automatically swings to the threading position (C).
- Pass the thread in front of the needle around the hook (D) from bottom to top.
- Release lever (B). (3)
- Pull the thread through the needle eye.

### Attention:

Turn power switch to off ("O")!

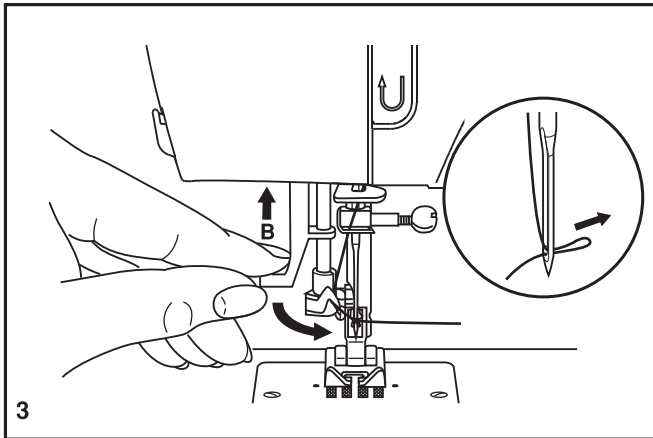

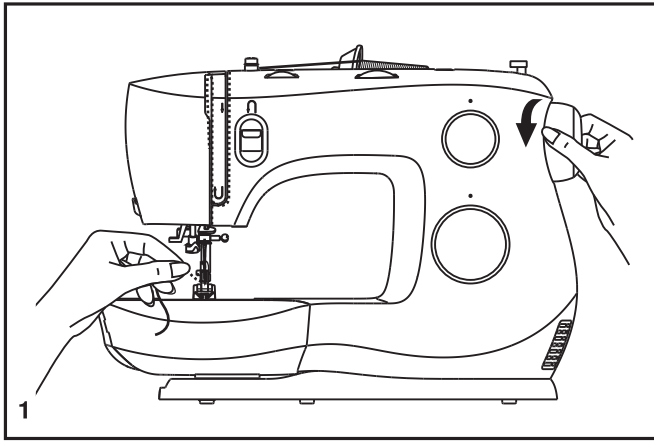

## □ Raising the Bobbin Thread

Hold the upper thread with the left hand. (1)

Turn the handwheel towards you (counterclockwise) lowering, then raising needle.

### **Note:**

If it is difficult to raise the bobbin thread, check to make sure the thread is not trapped by the hinged cover or the Removable Extension Table.

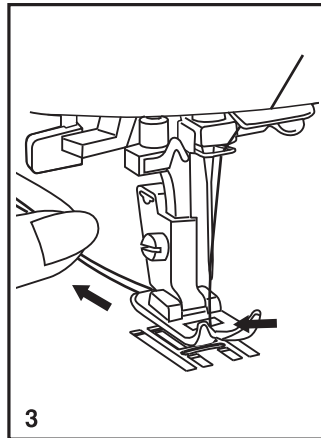
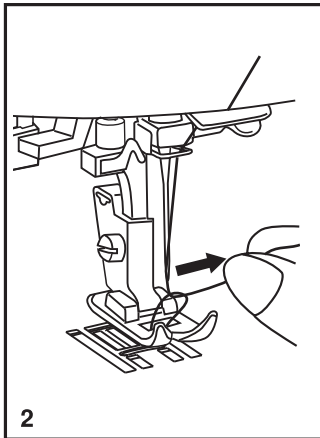

Gently pull on the upper thread to bring the bobbin thread up through the needle plate hole. (2)

Lay both threads to the back under the presser foot. (3)

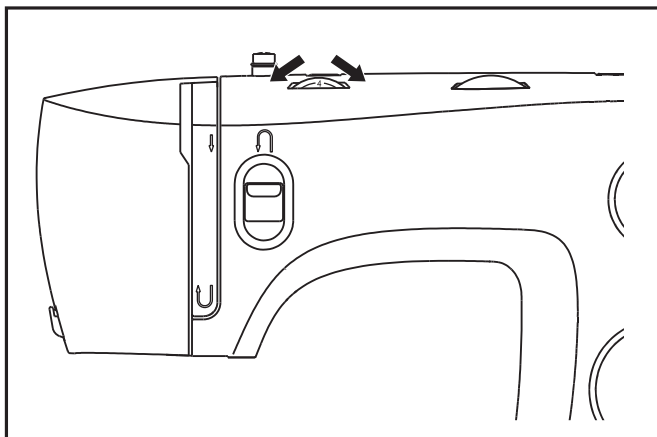

## □ Thread Tension

### Upper thread tension

Basic thread tension setting: "4".

To increase the tension, turn the dial to the next number up.

To reduce the tension, turn the dial to the next number down.

1. Normal thread tension for straight stitch sewing.
2. Thread tension too loose for straight stitch sewing. Turn dial to higher number.
3. Thread tension too tight for straight stitch sewing. Turn dial to lower number.
4. Normal thread tension for zig zag and decorative sewing.  
Correct thread tension is when a small amount of the upper thread appears on the bottom side of fabric.

### Lower thread tension

The bobbin tension has been set correctly at the factory, so you do not need to adjust it.

### Please note:

- Proper setting of tension is important to good sewing.
- There is no single tension setting appropriate for all stitch functions, thread or fabric.
- A balanced tension (identical stitches both top and bottom) is usually only desirable for straight stitch construction sewing.
- 90% of all sewing will be between "3" and "5".
- For zig zag and decorative sewing stitch functions, thread tension should generally be less than for straight stitch sewing.
- For all decorative sewing you will always obtain a nicer stitch and less fabric puckering when the upper thread appears on the bottom side of your fabric.

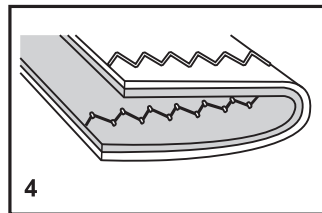
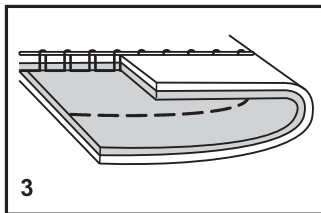
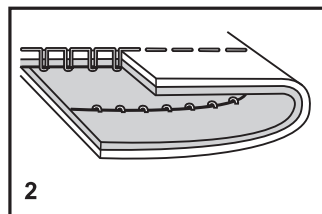
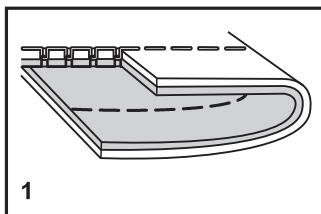

## □ How to Choose Your Pattern

The diagram on this page display the stitch patterns available on the machine.

Stitches in the top of the diagram are indicated on the Pattern Selector Dial in gray. To select the patterns indicated with the gray color, turn the Pattern Selector Dial. (d)

Use the Stitch Length Dial (c) to adjust the stitch length as desired for the project. Use the Stitch Width (b) to adjust the width of the stitch as desired.

To obtain the other patterns, turn the stitch length dial to “S1” or “S2” and select the pattern desired with pattern selector dial.

The Pattern Selector Dial may be turned in either direction.

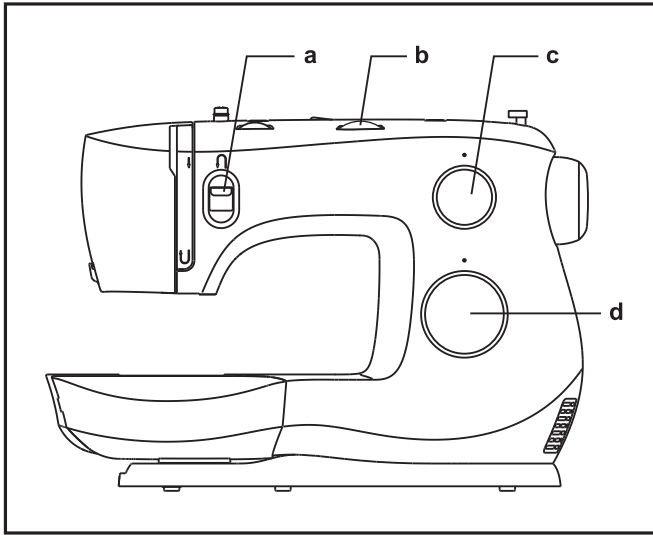

- a. Reverse Sewing Lever
- b. Stitch Width Dial
- c. Stitch Length Dial
- d. Pattern Selector Dial

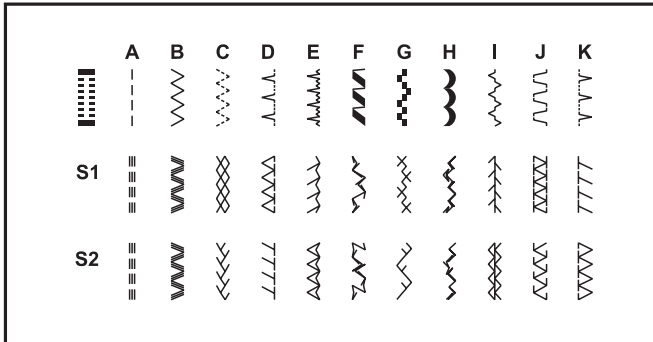

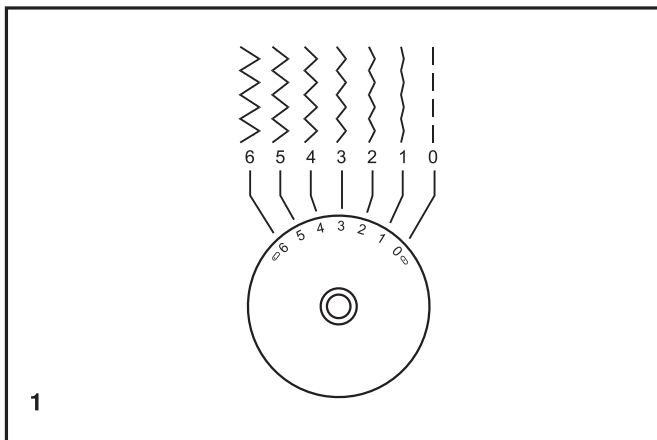

1

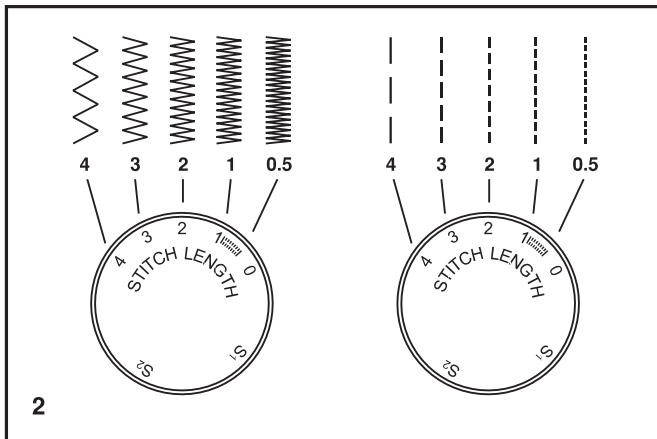

2

## □ **Stitch Width Dial & Stitch Length Dial**

### **Function of stitch width dial**

The maximum zigzag stitch width for zigzag stitching is 6mm; however, the width can be reduced on any patterns. The width increases as you move zigzag dial from “0” - “6”. (1)

The Stitch Width Dial is also the control for the straight stitch infinite needle position. “0” is center needle position, “6” is full left.

### **Function of stitch length dial while zig-zag stitching**

Set the Pattern Selector Dial to zig-zag.

The density of zig-zag stitches increase as the setting of stitch length dial approaches “0”.

Neat zig-zag stitches are usually achieved at “3” or below. (2)

Dense zig-zag stitches are called satin stitches. (2)

### **Function of stitch length dial for when straight stitching**

For straight stitch sewing, turn the Pattern Selector Dial to the straight stitch setting. Turn the Stitch Length Dial, and the length of the individual stitches will decrease as the dial approached “0”. The length of the individual stitches will increase as the dial approaches “4”. Generally speaking, use a longer stitch length when sewing heavier weight fabrics or when using a thicker needle or thread. Use a shorter stitch length when sewing lighter weight fabrics or when using a finer needle or thread.

## Sewing Straight Stitch

To begin sewing, set the machine for straight stitch. (1)

Place the fabric under the presser foot with the fabric edge lined up with the desired seam guide line on the needle plate. (2)

Lower the presser foot lifter, and then step on the foot controller to start sewing. (3)

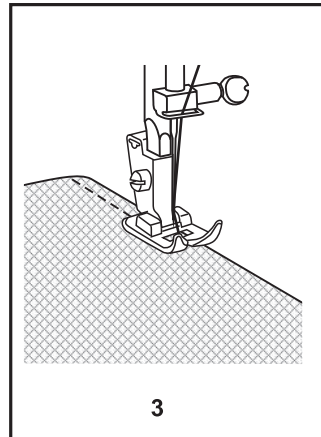
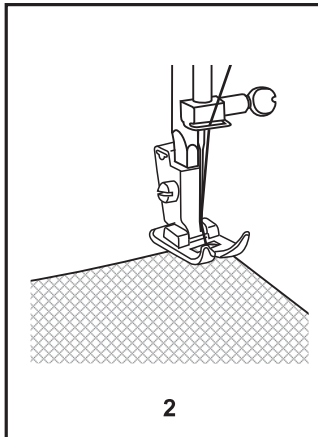
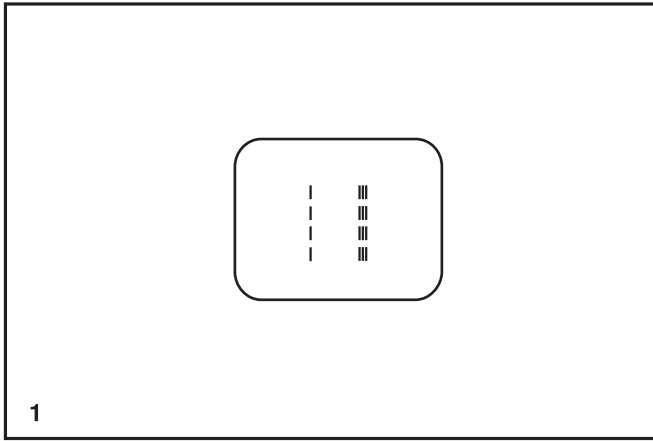

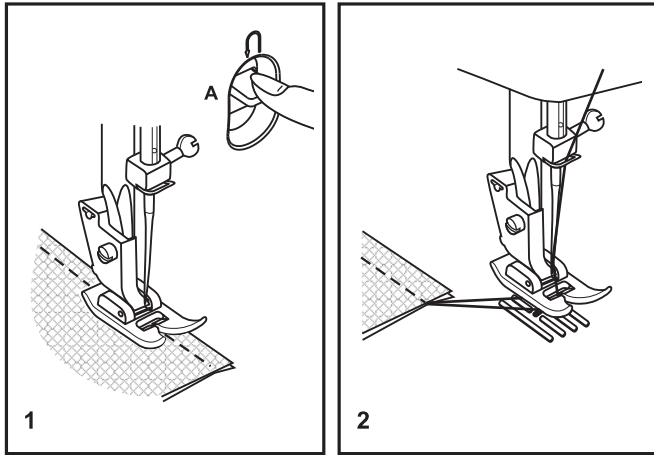

## Reverse Sewing

---

To secure the beginning and the end of a seam, press down the reverse sewing lever (A). Sew a few reverse stitches. Release the lever and the machine will sew forward again. (1)

## Removing the Work

---

Turn the handwheel toward you (counterclockwise) to bring the thread take up lever to its highest position, raise the presser foot and remove work behind the needle and presser foot. (2)

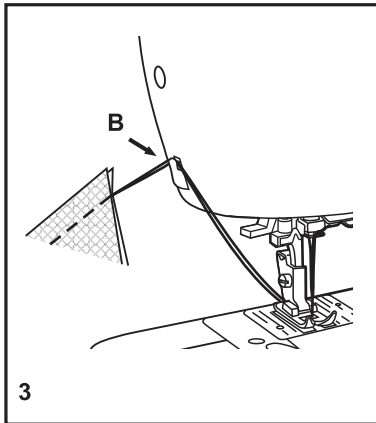

## Cutting the Thread

---

Pull the threads under and behind the presser foot. Guide the threads to the side of the face plate and into thread cutter (B). Pull threads down to cut. (3)

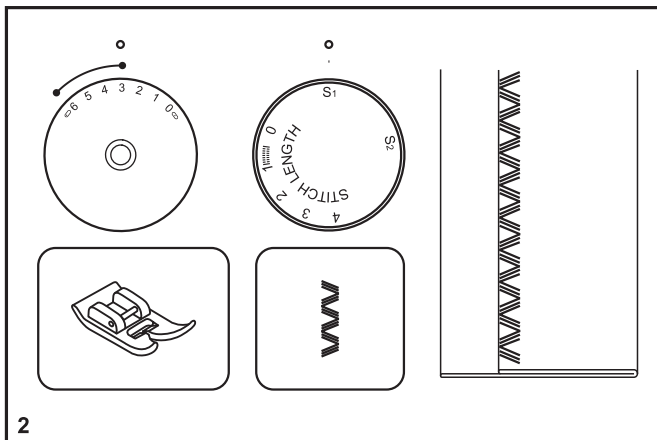
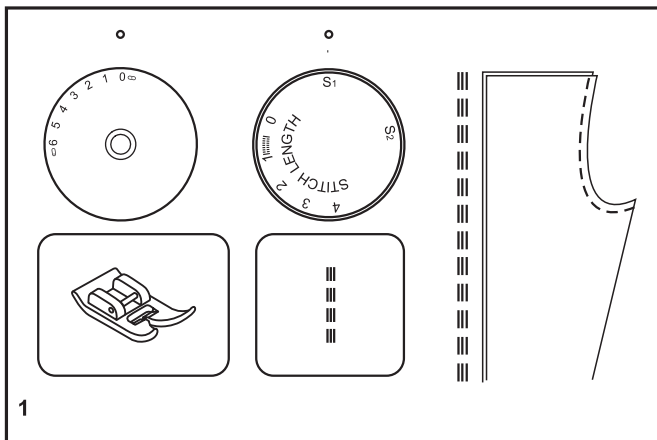

## □ Choosing Stretch Stitch Patterns

The stretch stitch patterns are indicated with blue and red colors on the pattern selector dial.

To select these stitches, turn the Pattern Selector Dial to the desired pattern. Then, turn the Stitch Length Dial to the indicator marked "S1" or "S2". Though there are several stretch patterns, here are two examples:

### **Straight Stretch Stitch (1)**

Set the Pattern Selector Dial to "  ".

Used to add triple reinforcement to stretch and hardwearing seams.

The machine sews two stitches forward and one stitch backwards.

### **Ric Rac (2)**

Set the Pattern Selector Dial to "  ".

Adjust the Stitch Width Dial to between "3" and "6".

Ric Rac Stitch is suitable for firm fabrics like denim, corduroy, poplin, duck, etc.



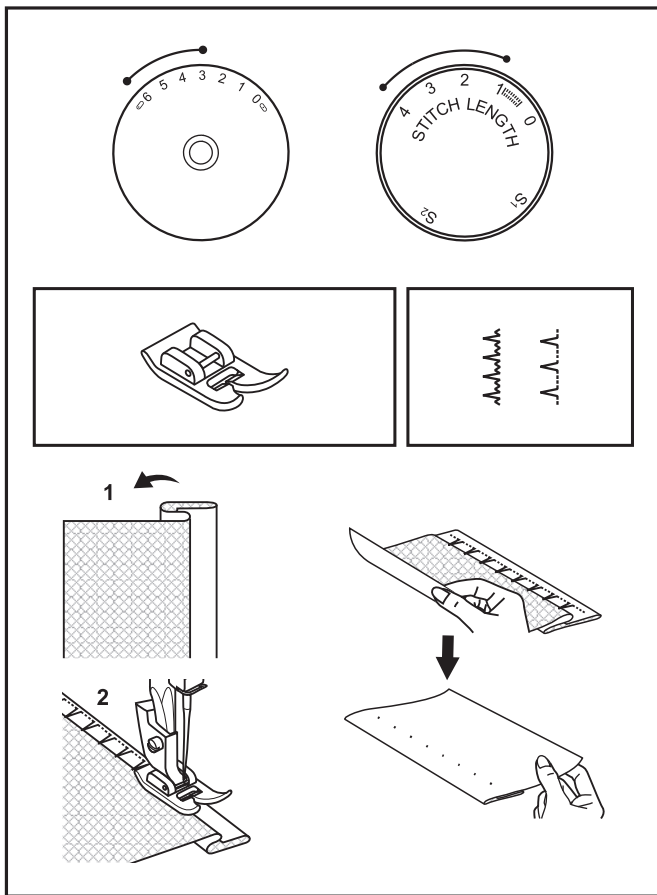

## □ Blind Hem

For hems on curtains, trousers, skirts, etc.

*~~~~~* Blind hem for stretch fabrics.

*.....* Blind hem for firm fabrics.

Set the Stitch Length Dial with the range shown on the diagram at the right. Blind hems, however, are normally sewn with a longer stitch length setting. Set the Stitch Width Dial at a setting appropriate for the weight/type of fabric being sewn, within the range shown in the diagram on the right of the page. Generally, a narrower stitch is used for lighter weight fabrics, and a wider stitch is used for heavier weight fabrics. Sew a test first to make sure the machine settings are appropriate for the fabric.

Blind Hem:

Turn up the hem to the desired width and press. Fold back (as shown in Fig. 1) against the right side of the fabric with the top edge of the hem extending about 7 mm (1/4") to the right side of the folded fabric.

Start to sew slowly on the fold, making sure the needle touches slightly the folded top to catch one or two fabric threads. (2)

Unfold the fabric when hemming is completed and press.

### **Note:**

To make blind hem sewing even easier, use a blind hem foot, available from your SINGER® retailer.



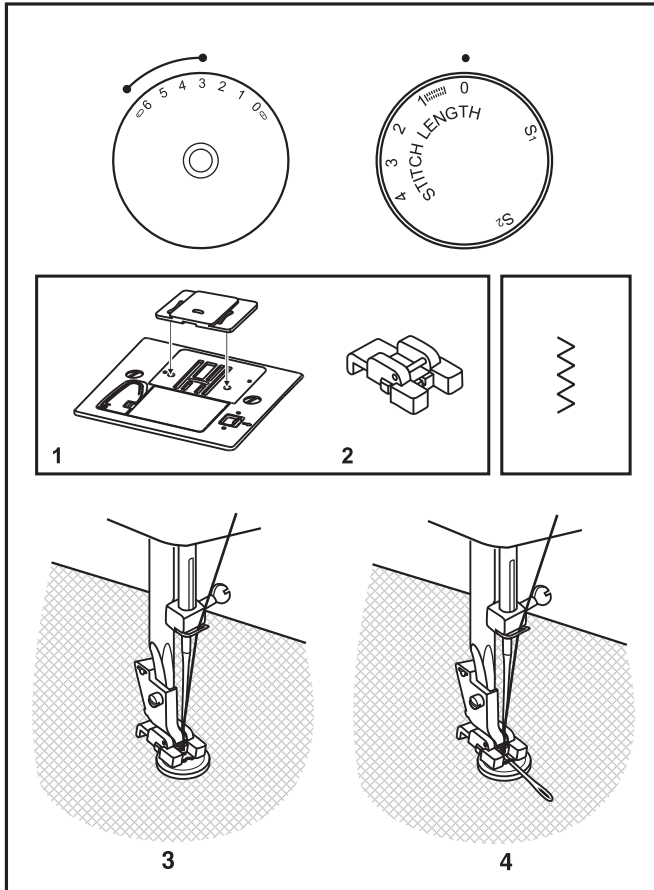

## □ Sewing on Buttons

Install the darning plate. (1)

Change the all purpose foot to the button sewing foot. (2)

Set the stitch length to "0".

Place the button and fabric under the Button Sewing foot, as illustrated in (3).

Set the machine for zig-zag stitch, then set the width to number "3" - "6". Turn the handwheel to check that the needle goes cleanly into the left and right holes of the button. Adjust the stitch width, as needed, according to the distance between the holes of the button. Slowly sew on the button with about 10 stitches.

Raise the needle out of the fabric. Set the machine for straight stitch again, then sew a few securing stitches to finish.

If a shank is required, place a darning needle on top of the button and sew (4) . For buttons with 4 holes, sew through the front two holes first, push the work forward and then sew through the back two holes.

## □ **Installing the Removable Extension Table**

Hold the removable extension table horizontally, and push it in the direction of the arrow. (1)

To remove the extension table, pull it toward the left.

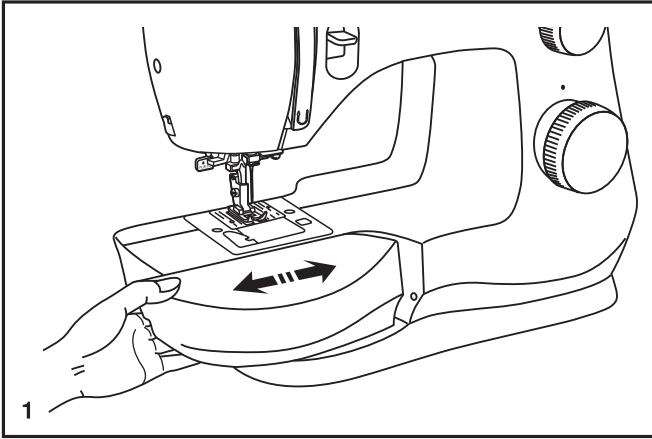

The inside of the removable extension table can be utilized as an accessory box.

To open, flip cover down as shown. (2)

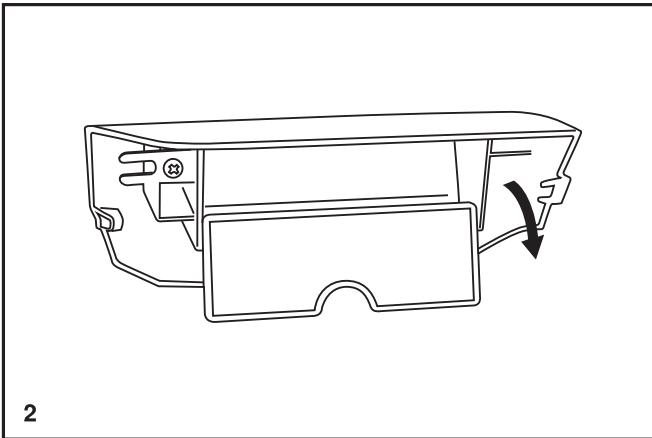

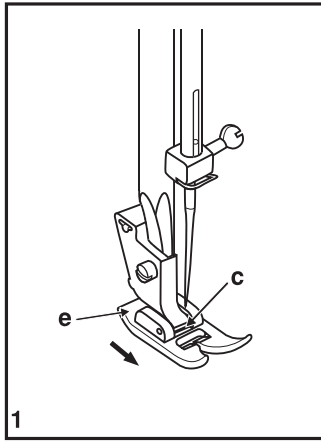

1

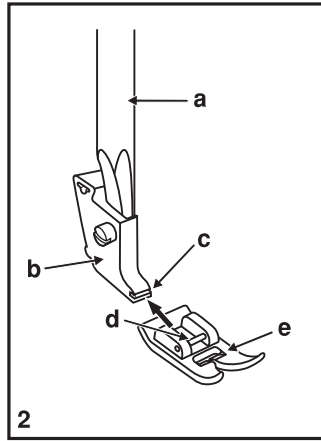

2

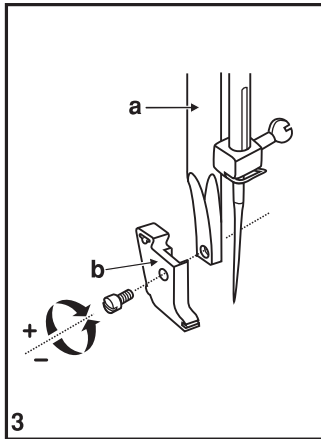

3

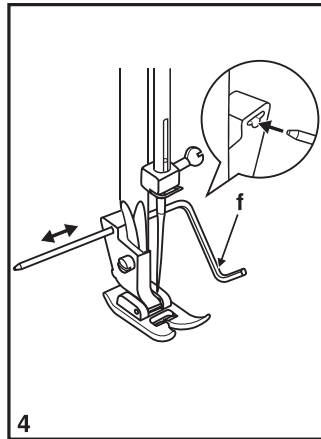

4

## □ Changing the presser foot

### Removing the presser foot

Push the presser foot (e) to disengage from the cut-out (c). (1)

### Attaching the presser foot

Install the pin (d) of the presser foot (e) into the cut-out (c) of the presser foot holder. (2)

### Removing and Attaching the presser foot shank

Raise the presser bar (a) with the presser foot lifter.

Remove and attach the presser foot shank (b) as illustrated. (3)

### Attaching the edge/ quilting guide

Attach the edge/quilting guide (f) in the slot as illustrated.

Adjust as needed for hems, pleats, quilting, etc. (4)

### Attention:

Turn power switch to off ("O") when carrying out any of the above operations!

## ☐ Needle/ Fabric/ Thread Chart

### NEEDLE, FABRIC, THREAD SELECTION GUIDE

NEEDLE SIZE	FABRICS	THREAD
9-11 (70-80)	Lightweight fabrics-thin cottons, voile, silk, muslin, interlocks, cotton knits, tricots, jerseys, crepes, woven polyester, shirt & blouse fabrics.	Light-duty thread in cotton, nylon, polyester or cotton wrapped polyester.
11-14 (80-90)	Medium weight fabrics-cotton, satin, kettlecloth, sailcloth, double knits, lightweight woolens.	Most threads sold are medium size and suitable for these fabrics and needle sizes. Use polyester threads on synthetic materials and cotton on natural woven fabrics for best results.
14 (90)	Medium weight fabrics-cotton duck, woolen, heavier knits, terrycloth, denims.	
16 (100)	Heavyweight fabrics-canvas, woolens, outdoor tent and quilted fabrics, denims, upholstery material (light to medium).	Always use the same thread on top and bottom.
18 (110)	Heavy woolen, overcoat fabrics, upholstery fabrics, some leathers and vinyls.	Heavy duty thread, carpet thread.

**IMPORTANT:** Match needle size to thread size and weight of fabric.

### NEEDLE, FABRIC SELECTION

NEEDLES	EXPLANATION	TYPE OF FABRIC
SINGER® 2020	Standard sharp needles. Sizes range thin to large. 9 (70) to 18 (110).	Natural woven fabrics-wool, cotton, silk, etc. Not recommended for double knits.
SINGER® 2045	Semi-ball point needle, scarfed. 9 (70) to 18 (110).	Natural and synthetic woven fabrics, polyester blends. Knits-polyesters, interlocks, tricot, single and double knits. Also sweater knits, Lycra®, swimsuit fabric, elastic.
SINGER® 2032	Leather needles. 12 (80) to 18 (110).	Leather, vinyl, upholstery. (Leaves smaller hole than standard large needle.)

#### Note :

1. For best sewing results always use genuine SINGER® needles.
2. Replace needle often (approximately every other garment ) and/ or at first thread breakage or skipped stitches.

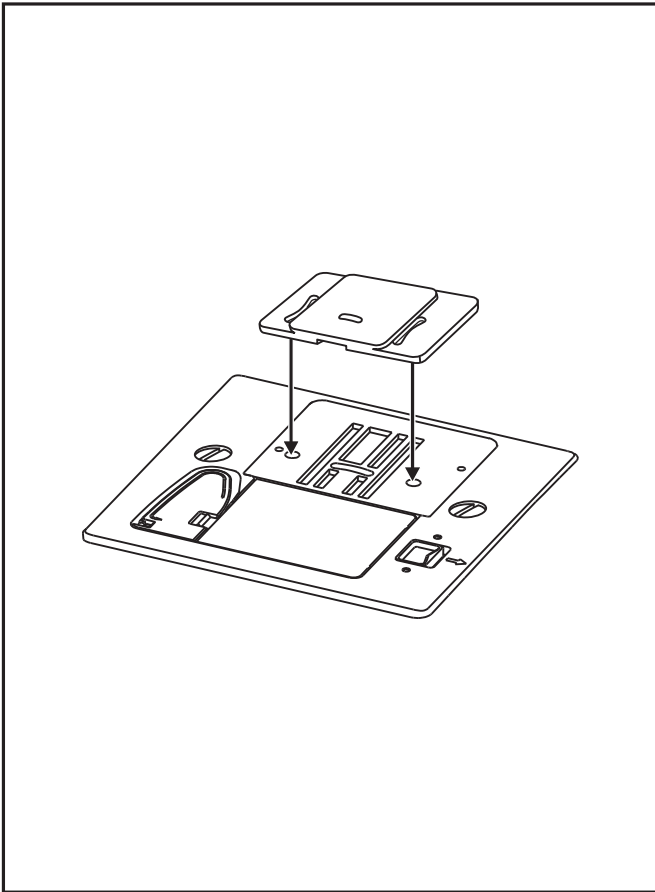

## □ Darning plate

---

For certain types of work, (e.g. darning or free-hand embroidery), the darning plate must be used.

Install the darning plate as illustrated.

For normal sewing, remove the darning plate.

For free-motion sewing it is recommended to use a darning/embroidery foot, available as an optional accessory from SINGER® retailers.

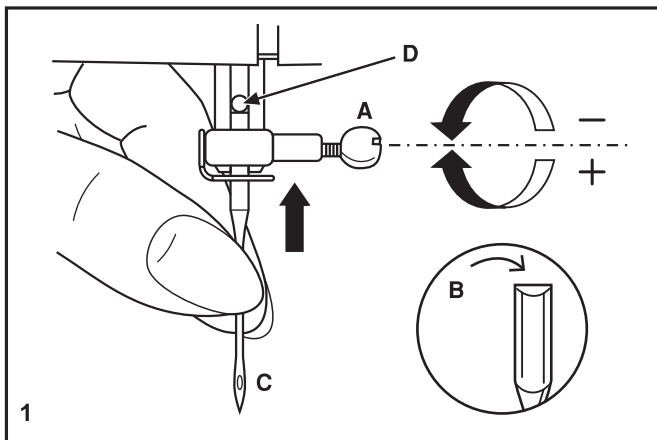

## □ Inserting the needle

Change the needle regularly, especially if it is showing signs of wear and causing problems. For best sewing results always use SINGER® Brand Needles.

Insert the needle as illustrated as follows:

- A. Loosen the needle clamp screw and tighten again after inserting the new needle. (1)
- B. The flat side of the shaft should be towards the back.
- C/D. Insert the needle as far up as it will go.

### **Attention:**

Turn power switch to off ("O") before inserting or removing the needle.

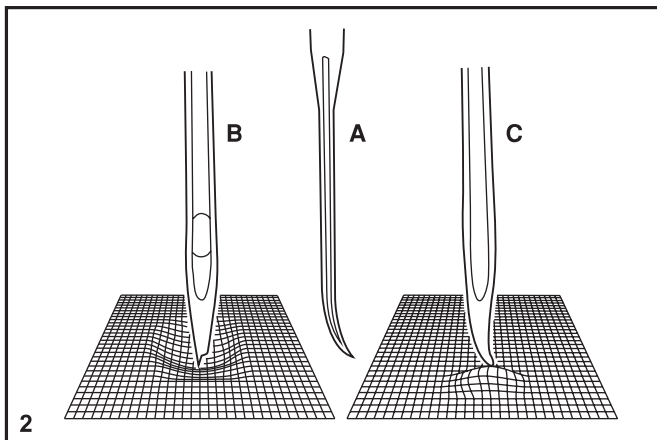

Needles must be in perfect condition. (2)

Problems can occur with:

- A. Bent needles
- B. Damaged points
- C. Blunt needles



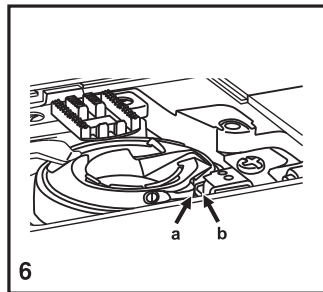
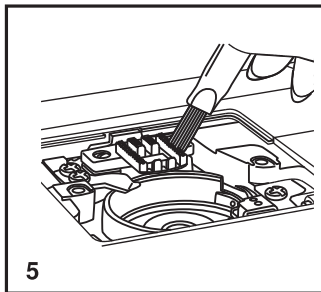
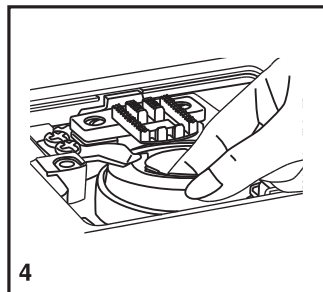
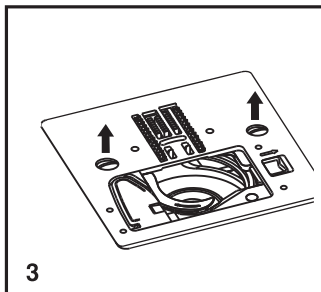
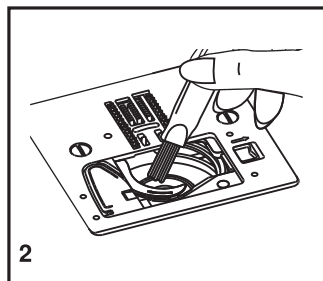
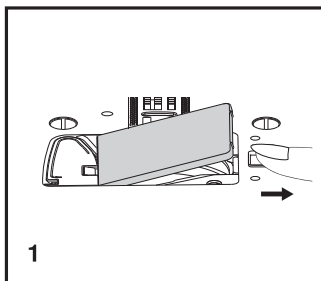

## □ Cleaning the Feed Teeth and Hook Area

If lint and bits of thread accumulate in the hook, this will interfere with the smooth operation of the machine.

Check regularly and clean the stitching mechanism when necessary.

### **Attention:**

Disconnect the machine from the wall outlet before carrying out any maintenance.

1. Remove the bobbin cover plate and bobbin.
2. Clean the bobbin holder with a brush.
3. Remove the needle, presser foot and presser foot holder. Remove the screw holding the needle plate and remove the needle plate.
4. Lift up the bobbin case and remove it.
5. Clean the hook race, feed dog and bobbin case with a brush. Also clean them, using a soft, dry cloth.
6. Replace the bobbin case into the hook race so that the tip (a) fits to the stopper (b) as shown.

## ☐ Troubleshooting Guide

---

<b>Problem</b>	<b>Cause</b>	<b>Correction</b>
Upper thread breaks	<ol style="list-style-type: none"><li>1. The machine is not threaded correctly.</li><li>2. The thread tension is too tight.</li><li>3. The thread is too thick for the needle.</li><li>4. The needle is not inserted correctly.</li><li>5. The thread is wound around the spool holder pin.</li><li>6. The needle is damaged.</li></ol>	<ol style="list-style-type: none"><li>1. Rethread the machine.</li><li>2. Reduce the thread tension. (lower number)</li><li>3. Select a larger needle.</li><li>4. Remove and reinsert the needle. (flat side towards the back)</li><li>5. Remove the reel and wind thread onto reel.</li><li>6. Replace the needle.</li></ol>
Skipped stitches	<ol style="list-style-type: none"><li>1. The needle is not inserted correctly.</li><li>2. The needle is damaged.</li><li>3. The wrong size or type of needle has been used.</li><li>4. The foot is not attached correctly.</li></ol>	<ol style="list-style-type: none"><li>1. Remove and reinsert needle. (flat side towards the back)</li><li>2. Insert a new needle.</li><li>3. Choose a needle to suit the thread and fabric.</li><li>4. Check and attach correctly.</li></ol>
Needle breaks	<ol style="list-style-type: none"><li>1. The needle is damaged.</li><li>2. The needle is not correctly inserted.</li><li>3. Wrong needle size for the fabric.</li><li>4. The wrong foot is attached.</li></ol>	<ol style="list-style-type: none"><li>1. Insert a new needle.</li><li>2. Insert the needle correctly. (flat side towards the back)</li><li>3. Choose a needle to suit the thread and fabric.</li><li>4. Select the correct foot.</li></ol>
Loose stitches	<ol style="list-style-type: none"><li>1. The machine is not correctly threaded.</li><li>2. The bobbin case is not correctly threaded.</li><li>3. Needle/ fabric/ thread combination is wrong.</li><li>4. Thread tension wrong.</li></ol>	<ol style="list-style-type: none"><li>1. Check the threading.</li><li>2. Thread the bobbin case as illustrated.</li><li>3. The needle size must suit the fabric and thread.</li><li>4. Correct the thread tension.</li></ol>
Seams gather or pucker	<ol style="list-style-type: none"><li>1. The needle is too thick for the fabric.</li><li>2. The stitch length is incorrectly adjusted.</li><li>3. The thread tension is too tight.</li></ol>	<ol style="list-style-type: none"><li>1. Select a finer needle.</li><li>2. Readjust the stitch length.</li><li>3. Loosen the thread tension.</li></ol>
Uneven stitches, uneven feed	<ol style="list-style-type: none"><li>1. Poor quality thread.</li><li>2. The bobbin case is incorrectly threaded.</li><li>3. Fabric has been pulled.</li></ol>	<ol style="list-style-type: none"><li>1. Select a better quality thread.</li><li>2. Remove bobbin case, thread and insert correctly.</li><li>3. Do not pull on the fabric while sewing, let it be drawn through by the machine.</li></ol>
The machine is noisy	<ol style="list-style-type: none"><li>1. Lint or oil have collected on the hook or needlebar.</li><li>2. The needle is damaged.</li></ol>	<ol style="list-style-type: none"><li>1. Clean the hook and feed dog as described.</li><li>2. Replace the needle.</li></ol>
The machine jams	Thread is caught in the hook.	Remove the upper thread and bobbin case, turn the handwheel backwards and forwards by hand and remove the thread.





Please note that on disposal, this product must be safely recycled in accordance with relevant National legislation relating to electrical/electronic products. Do not dispose of electrical appliances as unsorted municipal waste, use separate collection facilities. Contact your local government for information regarding the collection systems available. When replacing old appliances with new ones, the retailer may be legally obligated to take back your old appliance for disposal free of charge.

If electrical appliances are disposed of in landfills or dumps, hazardous substances can leak into the groundwater and get into the food chain, damaging your health and well-being.